



16" Outdoor Stand Fan

with Misting Feature

Owner's Manual

English

Model
90397

Form# 44095-01

R20101214

©2010 Hunter Fan Co.

SINCE 1886
Hunter[®]



INTRODUCTION

Thank you for choosing the Hunter Outdoor Stand Fan with Misting capability. Using your Hunter Fan will provide a soothing, cooling mist to any outdoor environment. For optimal cooling effects, the misting fan should be run with outdoor temperatures above 85°F and humidity levels below 85%.

- ✓ Misting nozzles for added cooling
- ✓ A powerful motor for maximum air flow
- ✓ Three speeds to adjust your comfort level
- ✓ Weather resistant construction

SAFETY AND WARNINGS

To reduce the risk of fire or electrical shock, **DO NOT** use this fan with any solid-state speed control device.

When using electrical appliances, basic precautions should **ALWAYS** be taken to reduce the risk of fire, electric shock, and personal injury.

Read and save these instructions!

1. Improper installation may result in the risk of fire, electric shock, or personal injury.
2. The power plug must be unplugged from the power socket when not in use, before cleaning, servicing, maintenance, and before moving to another location.
3. The fan should be placed on a flat, stable surface to avoid overturning.
4. Use fan only for intended use, as described in this instruction manual.
5. To protect against electrical shock, **DO NOT** immerse unit, plug, or cord in water.
6. Close supervision is necessary when any appliance is used by or near children.
7. NEVER insert fingers, pencils, or any other objects through the grill when the fan is running.



8. **DO NOT** operate any appliance with a damaged cord or plug, after the appliance malfunctions, or has been dropped or damaged in any manner.
9. To disconnect, grip plug and pull from wall outlet. **NEVER** pull directly on cord.
10. This product is intended for residential use only and not for commercial or industrial use.
11. **DO NOT** operate fan in the presence of explosive and/or flammable fumes, or freezing temperatures.
12. This appliance has a grounded three-prong plug and is suitable for grounded receptacle use only. **DO NOT** attempt to defeat the purpose of this safety feature.
13. **DO NOT** use an extension cord to plug this unit into an outlet.
14. This fan is provided with a ground fault circuit interrupter (GFCI) built into the plug of the power supply cord. This device provides additional protection from the risk of electric shock. **DO NOT** attempt to disconnect or bypass this safety feature.
15. **DO NOT** run the fan for extended periods of time unattended.
16. This fan is intended for outdoor use.
17. **DO NOT** attempt to mount or hang this fan from a wall or ceiling.
18. Exposure to sunlight for extended periods of time may fade the appearance of this product.



UNPACKING

As you unpack the fan, save the carton and packing materials in case you want to move or ship the unit in the future. Carefully remove all items from the box.

NOTE: It is best to have someone hold the box while you lift the fan and the protective packaging out of the carton. Make sure all shipping materials are removed from fan before operating.

PARTS LIST

Part	Name	Quantity
A	Front Grill	1
B	Blade Cap	1
C	Fan Blade	1
D	Plastic Nut	1
E	Rear Grill	1
F	Plastic Sleeve	1
G	Motor Shaft	1
H	Oscillation Knob	1
I	Motor Housing	1
J	Push Button	1
K	Thumb Screw	1
L	Power Cord	1
M	Waterproof Cover	1
N	Misting Line Holder	1
O	Internal Pole	1
P	Height Adjustment Knob	1
Q	External Pole	1
R	Misting Line	1
S	Valve	1
T	Stand Cover	1
U	Screws	4
V	Base	1

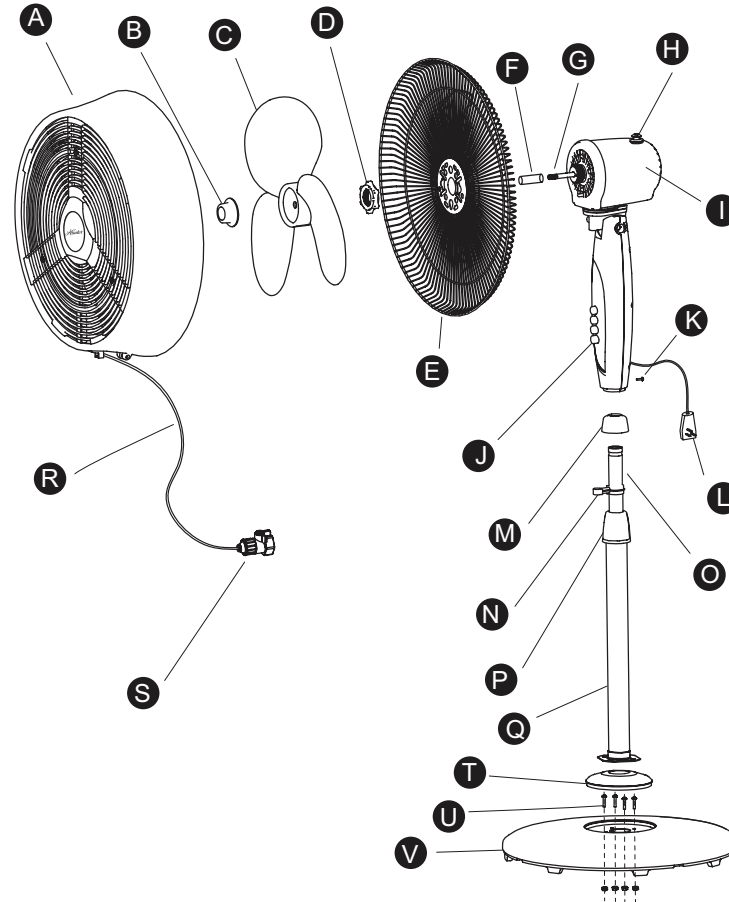

BASE ASSEMBLY (FIGURE 1.)

1. Unscrew the **Height Adjustment Knob (P)** on the **External Pole (Q)** and set aside. Attach the **External Pole (Q)** to the **Base (V)** by inserting and tightening the four **Screws (U)** included.
2. Slide the **Stand Cover (T)** over the **External Pole (Q)** into the ring on the **Base (V)**.
3. Use your finger to pull out the **Internal Pole (O)**. Slide the **Height Adjustment Knob (P)** over the **Internal Pole (O)**. Fasten it to the **External Pole (Q)** by turning the **Height Adjustment Knob (P)** clockwise while holding the **Internal Pole (O)**. Make sure the **Height Adjustment Knob (P)** is tightly fastened before final assembly.
4. Slide the **Waterproof Cover (M)** over the **Internal Pole (O)** until it covers the top of the **Height Adjustment Knob (P)**.

GRILL ASSEMBLY (FIGURES 2. & 3.)

1. Remove the **Blade Cap (B)** by turning clockwise, the **Plastic Nut (D)** by turning counterclockwise from the **Motor Housing (I)**, and the **Plastic Sleeve (F)** by pulling it straight off the **Motor Shaft (G)**. Discard **only** the plastic sleeve.
 2. Position the **Rear Grill (E)** over the **Motor Shaft (G)**, making certain the handle is at the top and the one notch in the center of the **Rear Grill (E)** cover fits over the three prong post on the **Motor Housing (I)**.
 3. Secure the **Rear Grill (E)** with the **Plastic Nut (D)** turning clockwise to tighten firmly.
 4. Slide the **Fan Blade (C)**, with the hollow interior of the blade facing towards the **Rear Grill (E)**, onto the **Motor Shaft (G)**. Line the cut-out on the back of the **Fan Blade (C)** with the retaining pin on the **Motor Shaft (G)**.
 5. Secure the **Fan Blade (C)** onto the **Motor Shaft (G)** by turning the **Blade Cap (B)** counterclockwise until it is firmly in place.
 6. Loosen the bolt on the bottom of the **Front Grill (A)** and mount the **Front Grill (A)** with the logo right side up to the **Rear Grill (E)** by snapping both together firmly.
- NOTE:** Ensure all snaps around the **Front Grill (A)** are secure on the **Rear Grill (E)**.
7. Tighten the bolt on the bottom of the **Front Grill (A)**.

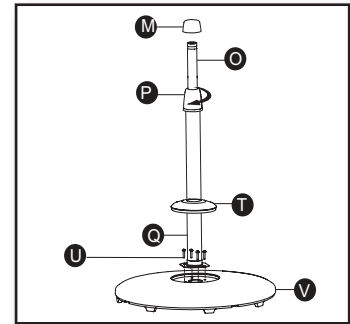

Figure 1.

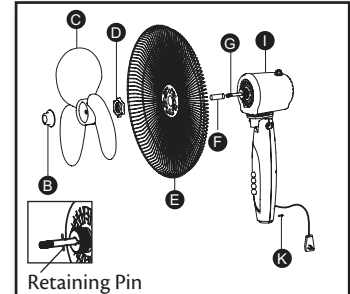

Figure 2.

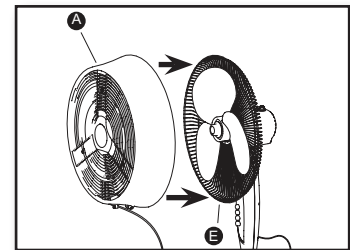

Figure 3.

FAN ASSEMBLY (FIGURE 4.)

1. Loosen the **Thumb Screw (K)** by turning it counterclockwise.
2. Insert the **Internal Pole (O)** into the neck joint of the **Motor Housing (I)** and tighten by turning the **Thumb Screw (K)** clockwise. Ensure it is tight enough to support the fan motor.
3. Attach the **Misting Line Holder (N)** onto the **Internal Pole (O)**.
4. Secure the **Misting Line (R)** to the clip under the **Front Grill (A)** and the **Misting Line Holder (N)**.

OPERATION AND ADJUSTMENTS

- Place the fan on a level surface. Plug the GFCI plug into a standard 120-volt AC 3-Prong wall outlet.
- Attach the **Valve (S)** onto a standard outdoor hose. Turn your water on at the spigot and use the lever on the **Valve (S)** to turn water on and off.
- To turn the fan on or adjust the speed setting, use the (H) high, (M) medium, (L) low, or (OFF) off buttons on the lower part of the **Motor Housing (I)**.
- To turn oscillation mode on, push the **Oscillation Knob (H)**. Pull the **Oscillation Knob (H)** up to turn oscillation off.
- Adjust the height of the fan by firmly gripping the **Internal Pole (O)**, loosening the **Height Adjustment Knob (P)** and adjusting the fan to the desired height. Fasten the **Height Adjustment Knob (P)** by turning it clockwise.

NOTE: ALWAYS ensure the **Waterproof Cover (M)** covers the **Height Adjustable Knob (P)** after adjusting the **Internal Pole (N)**.

- To adjust the angle of the fan, turn the fan off and grasp the motor assembly firmly and tilt up or down.

Caution: When not in use, turn the fan off and unplug it from the wall outlet. Turn the water off at the lever on the **Valve (S)** and at the water spigot and disconnect the **Valve (S)** from the hose.

GFCI Operation (Figure 5.):

The GFCI on the plug of this fan has 2 buttons: “Test” and “Reset”. If you wish to see if the GFCI circuit is functioning properly press the “Test” button. The fan will immediately shut off as if the GFCI has been activated and the window between the buttons will change to black. This lets you know the GFCI circuit has been activated. Press the “Reset” button and the fan can be turned on again and the window between the buttons will show orange. This indicates the GFCI circuit has not been activated and the fan should operate normally.

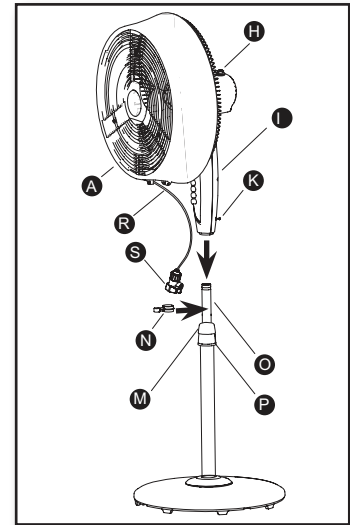

Figure 4.

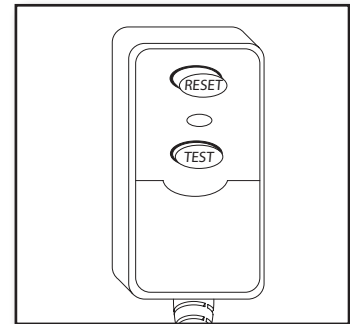

Figure 5.

MAINTENANCE

Warning! Before cleaning your Hunter fan, turn the unit off, unplug it, and disconnect the water hose from the misting valve. Never use harmful or abrasive chemicals and **ALWAYS** unplug the fan.

Fan Maintenance:

The fan body and grill can be cleaned with a slightly damp cloth. A mild dish detergent can be used if necessary. When cleaning the fan, ensure you **DO NOT** let excess water drip into the base of the motor where the controls are or into the motor compartment in the grill.

Misting Nozzle Maintenance:

1. To clean the misting nozzles, use a pair of needle nose pliers to twist each nozzle counterclockwise.
2. Once removed, soak the nozzles in white vinegar for 2 hours.
3. Rinse each nozzle with water and place back into the front fan grill.
4. Twist clockwise until secure. **DO NOT** over tighten.

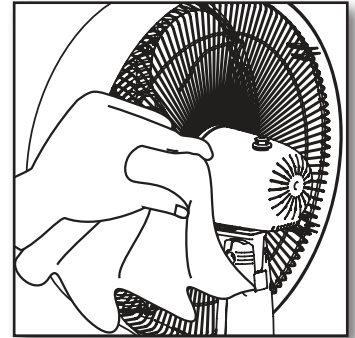

TROUBLESHOOTING

1. Problem

Misting feature sputters or does not mist at all.

Solution

- Ensure your outside water faucet is turned all the way on.
- Check the fan's valve lever and make sure it set open.
- Check your water hose for kinks or buckles.
- The valves on the fan may be clogged. Follow the instructions in the "Misting Nozzle Maintenance" section above.

2. Problem

Fan will not run.

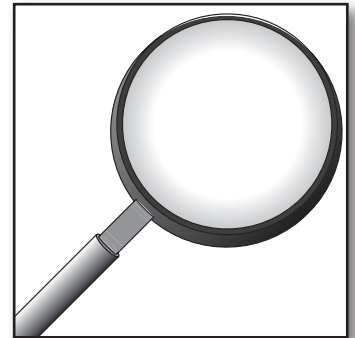

Solution

- Ensure the fan is plugged in.
- Check the GFCI on the fan's plug. If the window is black the GFCI has been tripped and needs to be reset. Press the "Reset" button on the plug. If the GFCI window is orange then the circuit is active and does not need to be reset.

3. Problem

Fan will not oscillate.

Solution

- Ensure the oscillation knob on the fan is pressed in.

4. Problem

GFCI continues to activate.

Solution

- Try using a different power outlet.
- Unplug the unit and contact our Technical Support Department.

If you have tried troubleshooting your problem and are still unable to resolve your issue, contact our Technical Support Department.

TECHNICAL SUPPORT

If you have any additional questions or problems with your Hunter Portable Fan, please call:

USA: 1-888-830-1326

Canada: 1-866-268-1936

Hours of operation are from 7:00 am to 7:00 pm Monday - Friday and 8:00 am to 5:00 pm on Saturday, Central Time. You may also contact us over the Internet at www.hunterfan.com.



WARRANTY

The Hunter Fan Company makes the following limited warranty to the user or consumer purchaser of this Hunter Portable fan:

If your Hunter Portable Fan motor fails at any time within one year after the date of sale to you due to a defect in material or workmanship, labor to repair the defect will be provided free of charge at our nearest service center or our Service Department in Memphis, Tennessee. You will be responsible for labor costs after this one-year period. The foregoing limited warranty applies only to the motor itself, and does not apply to electronic controls such as remote controls, remote control receivers or transmitters used in conjunction with the motor. These electronic control items are included in the one year limited warranty below.

If any part of your Hunter Portable Fan other than the motor fails at any time within one year after the date of sale to you due to a defect in material or workmanship, we will repair or, at our option, replace the defective part free of charge for parts and labor performed at our nearest service center or at our Service Department in Memphis, Tennessee.

IF THE USER OR CONSUMER PURCHASER CEASES TO OWN THE FAN, THIS WARRANTY AND ANY IMPLIED WARRANTY WHICH THEN REMAINS IN EFFECT, INCLUDING BUT NOT LIMITED TO ANY IMPLIED WARRANTY OF MERCHANTABILITY OR FITNESS FOR A PARTICULAR PURPOSE, ARE VOIDED. NO WARRANTY, EXPRESSED OR IMPLIED, INCLUDING ANY WARRANTY OF MERCHANTABILITY OR FITNESS FOR A PARTICULAR PURPOSE, IS MADE IN RESPECT TO THE GLASS GLOBES OR LIGHT BULBS OR THE FINISH ON ANY METAL PORTION OF THE FAN. THIS WARRANTY IS IN LIEU OF ALL OTHER EXPRESS WARRANTIES. THE DURATION OF ANY IMPLIED WARRANTY, INCLUDING, BUT NOT LIMITED TO ANY IMPLIED WARRANTY OF MERCHANTABILITY OR FITNESS FOR A PARTICULAR PURPOSE, IN RESPECT TO ANY HUNTER FAN MOTOR OR OTHER FAN PART, IS EXPRESSLY LIMITED TO THE PERIOD OF THE EXPRESS WARRANTY SET FORTH ABOVE FOR SUCH MOTORS AND OTHER PARTS.

This warranty is voided if your Hunter Fan is not purchased and used in the USA.

This warranty excludes and does not cover defects, malfunctions or failures of any Hunter Portable fan which were caused by repairs by persons not authorized by us, use of parts or accessories not authorized by us, mishandling, improper installation, modifications, or damage to the Hunter Portable fan while in your possession, or unreasonable use, including failure to provide reasonable and necessary maintenance.



To obtain servicing, contact the nearest Hunter authorized service center or the Hunter Fan Company Service Department, 7130 Goodlett Farms Pkwy. Suite 400, Memphis, Tennessee 38016. Please contact us before shipping your fan to us. If we authorize you to ship it to us, you will be responsible for all insurance and freight or other transportation charges to our factory service center. We will return your Hunter Fan freight prepaid. Your portable fan should be properly packed to avoid damage in transit since we will not be responsible for any such damage. Proof of purchase is required when requesting warranty service. The purchaser must present sales receipt or other document that establishes proof of purchase.

IN NO EVENT SHALL HUNTER FAN COMPANY BE LIABLE FOR CONSEQUENTIAL OR INCIDENTAL DAMAGES.

SOME STATES DO NOT ALLOW LIMITATIONS ON HOW LONG AN IMPLIED WARRANTY LASTS OR THE EXCLUSION OR LIMITATION OF INCIDENTAL OR CONSEQUENTIAL DAMAGES SO THE ABOVE LIMITATION MAY NOT APPLY TO YOU.

THE WARRANTY GIVES YOU SPECIFIC LEGAL RIGHTS AND YOU MAY ALSO HAVE OTHER RIGHTS WHICH VARY FROM STATE TO STATE.



PRODUCTS

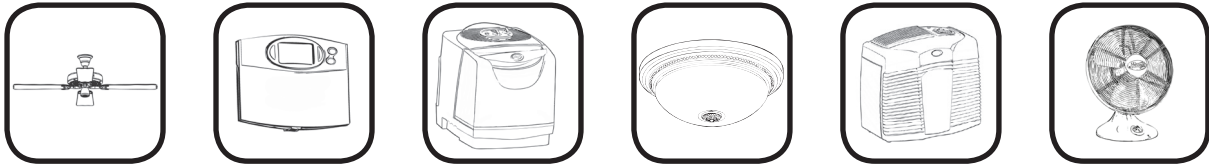

To learn more about Hunter Fan Company products, please see our Web page at:

www.hunterfan.com



7130 Goodlett Farms Pkwy., Suite 400
Memphis, Tennessee 38016

Printed in China and Taiwan